

LOW-ANGLE RING LIGHT

LA-120

Designed for a homogeneous, towards-centre, illumination. Suitable for OCR text illumination or flawless lighting of remote objects and surfaces.

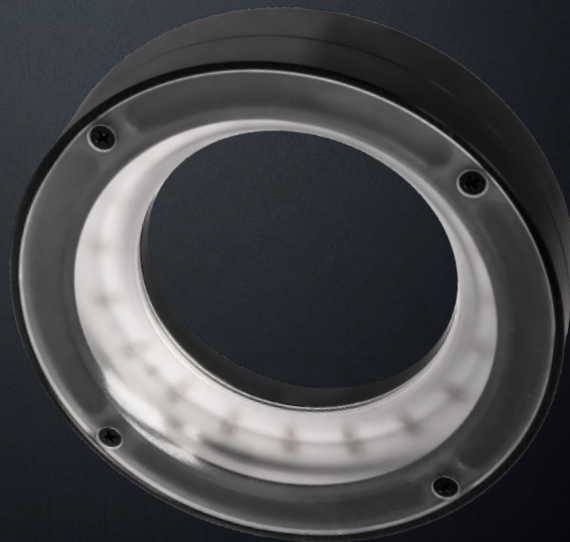

HI-PERFORMANCE LOW-ANGLE RING LIGHT

ANALOG ILLUMINATION INTENSITY CONTROL

STROBE MODE OPERATION

LIGHT OPERATING MODES

PERMANENT ILLUMINATION MODE

This light is designed for both the permanent and light-triggering mode. For permanent illumination bring the voltage of 10-24 V to the pin number 4 (black wire). The light is ON during the time when the 24 V EN signal is activated. Use a PCL, camera or another binary signal source. For the light intensity control, please see the text below.

LIGHT TRIGGERING MODE

Light triggering mode saves energy and extends the lifetime of the light. Trigger operation mode is recommended when a parallel operation of 2 or more lights might affect the quality of the acquired image. To start using a triggering mode, bring the pin number 4 (black wire) to a 10-24 V signal. The light is ON when a voltage of 24 V is present at pin number 4 then. Use a PCL, camera, or another binary signal source for triggering. For the light intensity control, please see the text below.

STROBE MODE

Strobe function significantly multiplies the maximum intensity of the light. The strobing function saves energy, extends the light lifetime and in many cases improves the stability of the entire inspections system. Pin number 2 (white wire) of the M8 connector is used to activate the strobe function. The maximum strobe pulse time is 10 ms, while the light idle time must be at least 10 times longer, which in this case makes 100 ms. Bringing a permanent logical 1 signal (10-24 V voltage) to a light strobe input, the light standardly operates in a 10 ms ON and 100 ms OFF cycle. The strobe operation pulse might be chosen in the time span of 1-10 ms. Please do not use a trigger mode during strobing function, do not bring a voltage to the pin number 3.

LIGHT SOURCE INTENSITY REGULATION

The light intensity might be regulated by an analogue voltage, PWM signal or an external controller. In case of using an analogue signal, the light intensity might be regulated in a linear way at a pin number 4 by the voltage span of 2.7 -10 V. Bringing a voltage of 10-24 V to the pin number 4, the light works at its maximum intensity. The maximum PWM frequency is ≤ 40 kHz.

WAYS OF USE

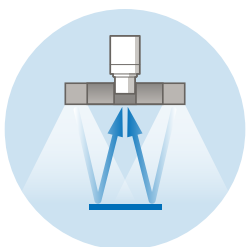

ORDERING CODE

example of the ordering code

LA - 120

B

Low-Angle Ring Light Ø of Active Area Wavelength

CONFIGURATION

Model	Wavelength [nm]	LED Beam Angle [°]
LA-120W	CTR 5000 k	120
LA-120HIR	940	120
LA-120IR	850	120
LA-120HR	660	120
LA-120R	625	120
LA-120G	528	120
LA-120B	470	120

ELECTRIC PARAMETERS

Model	LA-120W	LA-120HIR	LA-120IR	LA-120HR	LA-120R	LA-120G	LA-120B
U_n Voltage Span	16-28 V	16-28 V	16-28 V	16-28 V	16-28 V	16-28 V	16-28 V
U_{jm} Nominal Voltage	24 V DC	24 V DC	24 V DC	24 V DC	24 V DC	24 V DC	24 V DC
I_{jm} Nominal Current	660 mA	625 mA	700 mA	700 mA	700 mA	600 mA	600 mA
P Input	15.8 W	15 W	16.8 W	16.8 W	16.8 W	14.4 W	14.4 W

U_{trig} Trigger Voltage	≥ 10 - 24 V ²	I_{trig} Trigger Current	2.3 mA ²	U_{EN} Analogue Dimming	≥ 2.7 .. ≤ 10 V ²
U_{str} Strobe Voltage	3 - 24 V ³	I_{str} Strobe Current	1.9 mA ³	I_{EN} PWM Dimming	> 10 V .. ≤ 24 V ¹

¹ PWM maximal rate is ≤ 40 kHz ² EN (Enable) trigger signal values, M8 connector - pin number 4 ³ Driving voltage and current M8 connector - pin number 2

DIMENSIONS & WEIGHT

A Outer Ø [mm]	172
B Inner Ø [mm]	120
C Height [mm]	28
 Weight [g]	433

i For more details please see our 2D drawings.

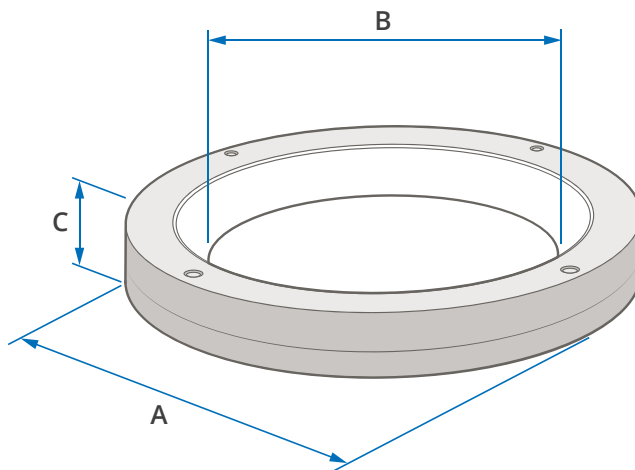

TECHNICAL DATA

IP Category: IP50	Protection Category: III	Ambient Temperature: -20 - +40 °C	Isolation Resistance: 500 V	Housing Material: Aluminium alloy
--------------------------	---------------------------------	--	------------------------------------	--

CONNECTOR M8-4PIN ASSIGNMENT

light connector front view

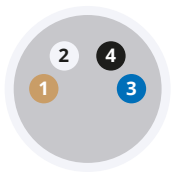

1	Brown	+	+24 V
2	White		EN
3	Blue	-	0 V
4	Black		EN

...

2 ENABLE - strobe mode (+24 V)

...

4 ENABLE

A permanent lighting or trigger signal (10-24 V)

B light intensity regulation: analogue signal 2.7-10 V or PWM \leq 40 kHz

ACCESSORIES

✓ Straight Cable M8-4PIN (5 m)

OPTIONAL ACCESSORIES

+ Angular Cable M8-4PIN (5 m)

+ Controller **Smart Light CT-SL4D**

+ Controller **CM-01**

 SmartView

**YOUR
VISION
PARTNER**



**COMPANY
OFFICE**

Smart View s.r.o.
Nivy 313
765 02 Otrokovice
Česká republika

+420 601 575 797
+420 602 457 497

info@smartview.cz
www.smartview.cz

**OUR SALES PARTNERS
SLOVAKIA**

MTS, spol. s r.o.
Krivá 53
027 55 Krivá
Slovensko

+421 43 5819 111

mts@mts.sk
www.mts.sk